

aussie
lifts



STAY IN THE
HOME YOU LOVE

Australian made residential
and commercial elevators

LOW UP VPL

A LIFE-CHANGING & VALUE-ADDING INVESTMENT



 Parkett vänster

LOW UP VPL

ACCESSIBLE, STYLISH & LUXURIOUS SINCE 1995

The "LOW UP" is a reliable low-rise lift (0-500mm) designed for safety and user control. Equipped with protective edges, roll-off protection, and handrails, it ensures secure and comfortable operation.

Customization options include two platform widths (715mm or 915mm) and a low 35mm threshold height. You can choose a wanderlead with a spiral cable for controls or add wireless call stations for seamless communication. So you're in complete control of your journey.

The standard design features durable brushed stainless steel with a checked aluminum plate flooring, making it suitable for indoors and outdoors use.

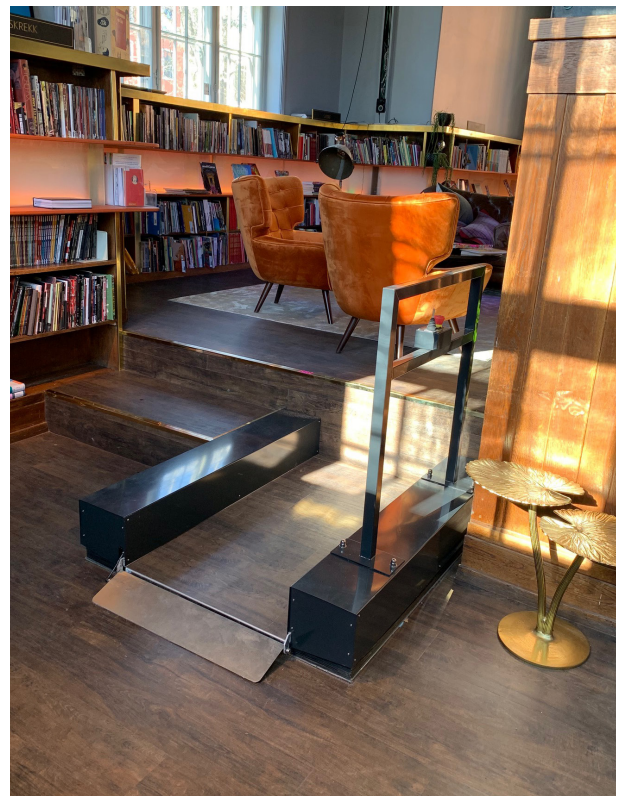

RESIDENTIAL LIFT PROMISE

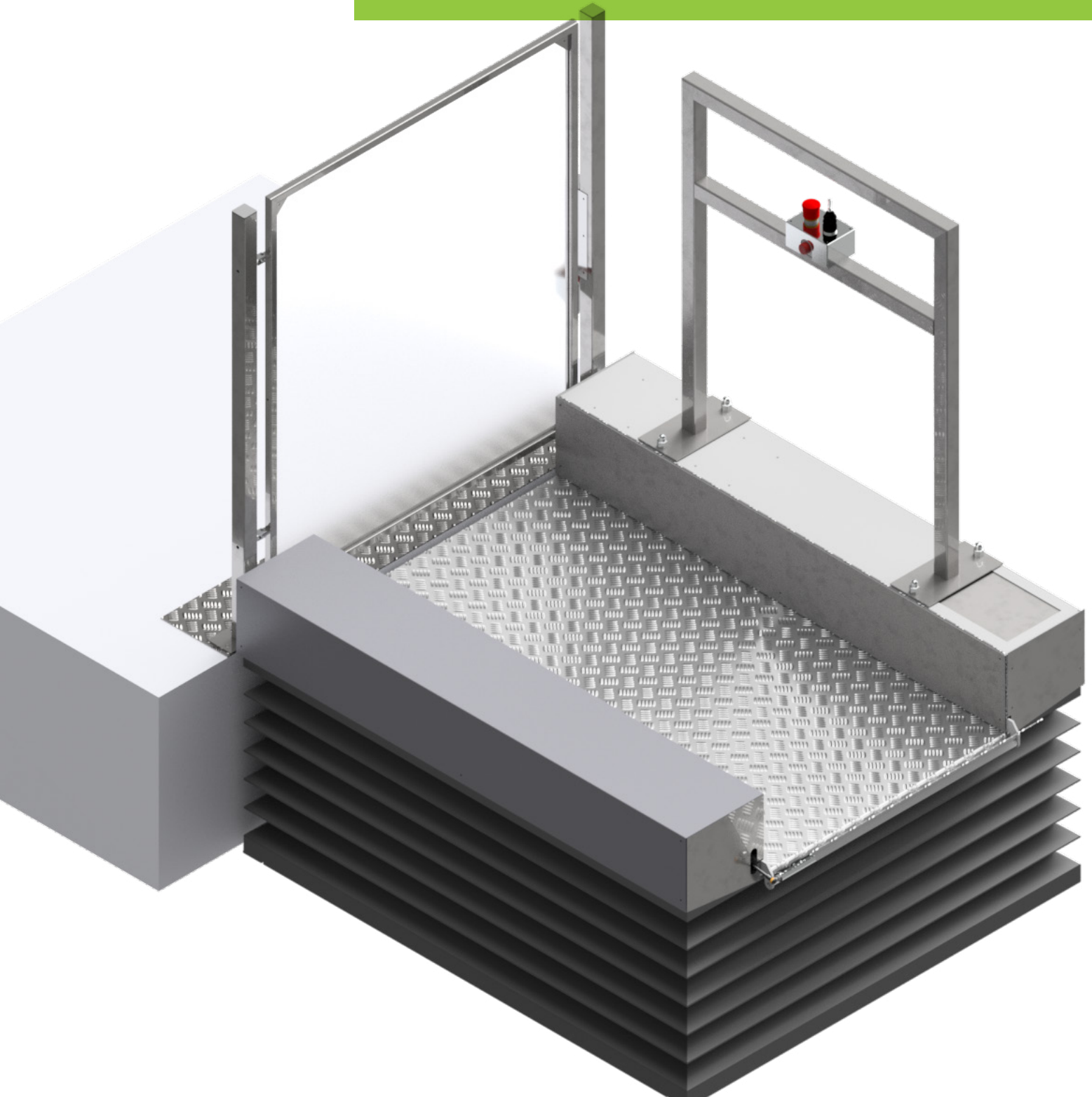



AUSTRALIAN DESIGNED AND MADE

Our low-maintenance lifts are designed and built locally to the highest standards. As one of the few non-importers in the market, every model exceeds Australian Standards (Part 12, 14, 16, 17 and 18) and is BCA compliant (BCA E3.3 & E3.6) for disability access.



FAST AND PROFESSIONAL

An Aussie Lift is manufactured, delivered and installed three times faster than imports. We can have your product to you from eight weeks, compared to the 26-week turnaround of competitors.



LEADING WARRANTY AND LOCAL SUPPORT

Our quality guarantees are second to none in the industry. If you ever do need replacement parts, they're available right here – minimising downtime and delays, compared to waiting for components from overseas.



COST-EFFECTIVE AND SIMPLE

Every Aussie Lift has low installation, maintenance and running costs – with just annual servicing required. They also don't need load-bearing walls or machine rooms, which makes them suitable for more homes.

LOW UP VPL

TECHNICAL INFORMATION

Weight Capacity: Up to 250kg

Lift Speed: 0.01m/s

Max Travel: 500mm

Lifting Equipment: 2pcs of linear actuators

Control Voltage: 24V DE

Control: Joy-stick maneuver

STANDARD MEASUREMENTS

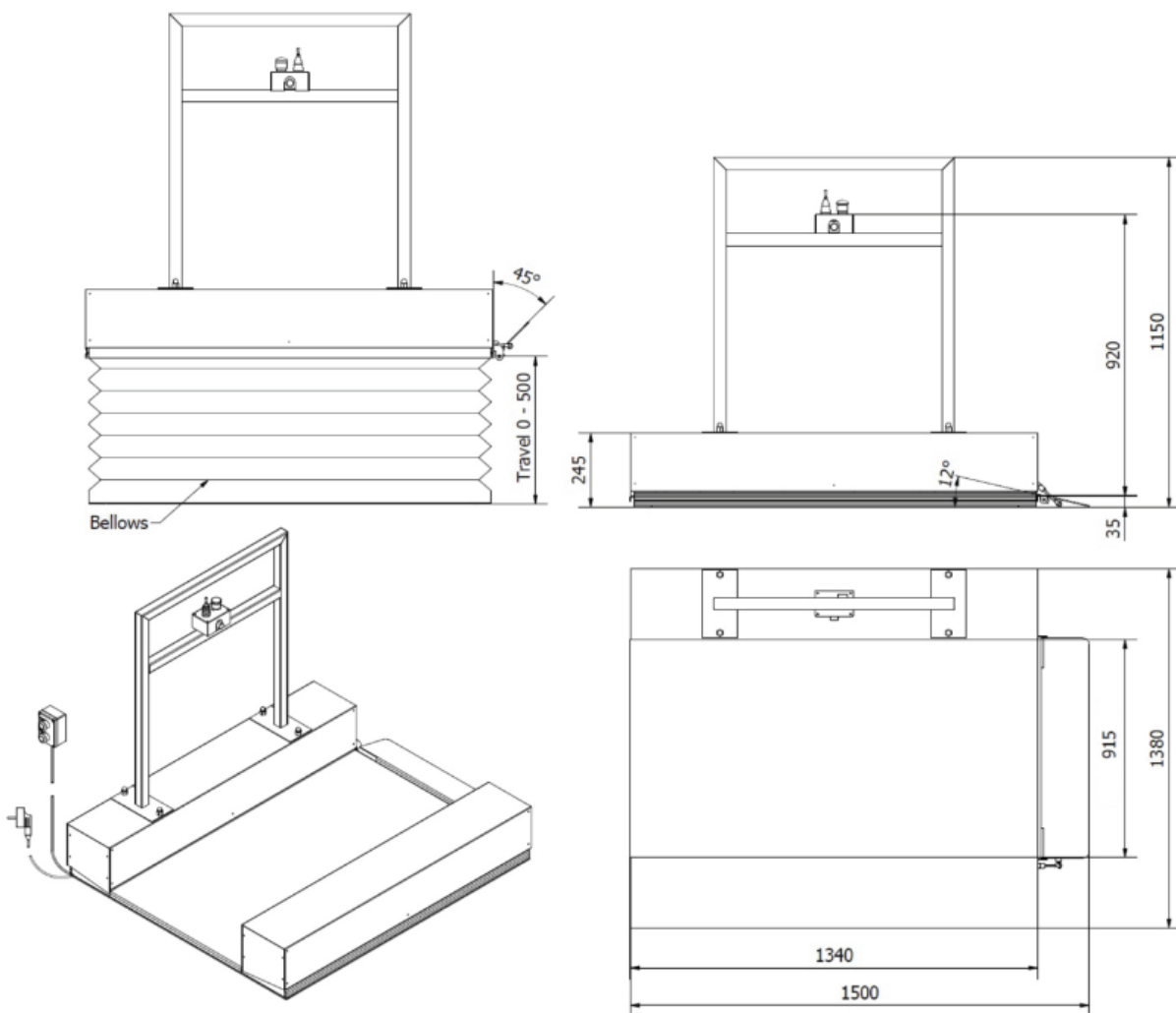

SAFETY FEATURES



Supplied with an impressive list of standard safety features, the Low up offers peace of mind with its in-car emergency telephone, emergency backup battery systems, and emergency lowering facilities.

PEACE OF MIND



European quality. Industry-leading Warranty. Custom built to your specification. Unrivalled after-sales service.

INSTALLATION



Supplied, assembled and pretested, the design of the Low up allows for easy installation by either craning in as a single piece or by dismantling and reassembling. Installation can be completed within as little as one day.

COST EFFECTIVE



Self Supporting Shaft - no load-bearing walls required. No separate machine room construction required. Lift is pre-assembled and commissioned at our factory before dispatch to site. Low service costs and power consumption.

MAINTENANCE



For optimum performance, reliability, and long term use, the lift should be serviced every 12 months by an approved lift technician.

CUSTOMISATIONS



Each lift is custom designed and constructed to your requirements with an impressive list of options available

LOW UP

OPTIONS

The automatic gate is the newest addition to the wide range of options available with the Low Up lift, offering an alternative to the manual gate.

Here's how it functions: when the lift reaches the upper threshold, the lock is automatically disengaged.

With manual gate, you can easily open it by hand. However, with the automatic gate, the door effortlessly swings open on its own, proving added convenience and ease of use.

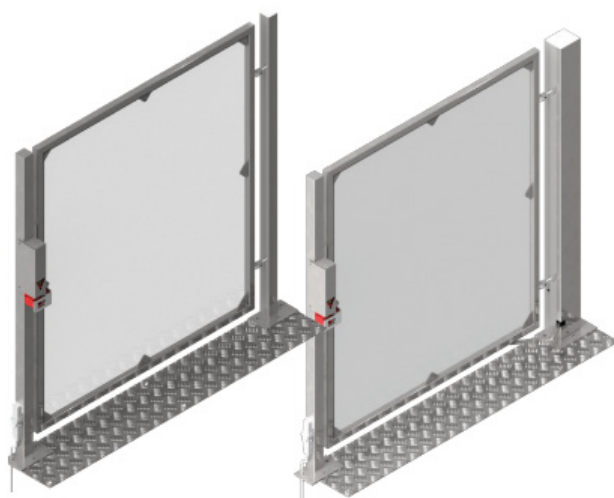

Manual Gate

Automatic Gate

OVERVIEW

MAX TRAVEL DISTANCE

500mm

DRIVE SYSTEM

2pc Linear Actuator

LIFT SPEED

0.01 m/sec

CAPACITY

Up to 250kg

CONTROL

Joy-Stick maneuver

CONTROL VOLTAGE

24 Volts DE

UPVPL



aussie
lifts



CALL US

1800 287 543



EMAIL US

info@aussielifts.com.au

